



# AT X1-16

Clip Specifications	
Bolt Grade	8.8
Max Side Load Capacity (kN)	120
Bolt Torque (Nm)	200
Horizontal Rail Adjustment (mm)	15

## Product Description

The X1-16 adjustable crane rail clip from Atlantic Track is specifically engineered to secure heavy rails on narrow girders, even in the most demanding applications. It can withstand a formidable lateral force of 120kN.

Its **low-profile** design enables compatibility with cranes equipped with guide rollers. The well-established '**double wedge**' design ensures self-locking and self-tightening when under load, providing lateral fixation for the rail. Simultaneously, a specially formulated vulcanized rubber nose applies a controlled force to the rail for enhanced stability.

## Dimensional data

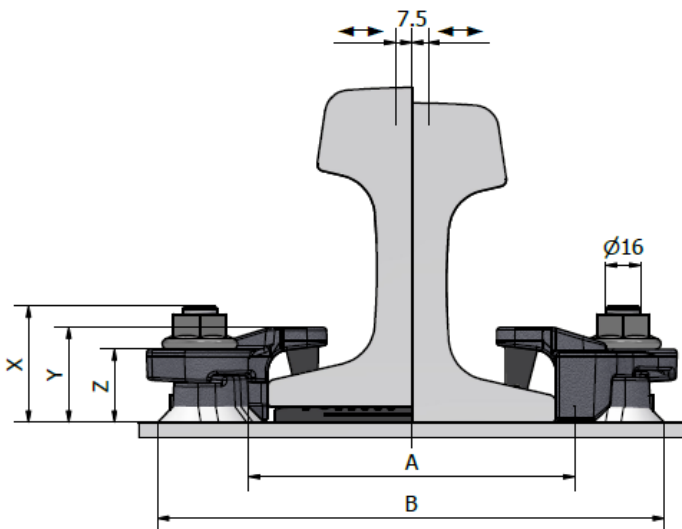

<b>Distance Between Bases (A) = Rail width + 16mm</b>
<b>Minimum Plate Width (B) = Rail width + 100mm</b>



1. Welded Clip Base    2. Clip Cap with integral rubber nose

## Features

- **Standard M16 or 5/8" bolts** in combination with flange nuts act together to lock the two parts.
- The clip has a proven self-tightening mechanism to **prevent loosening** over time.
- Drain hole to prevent build-up of contaminants and standing water.
- Atlantic Track's special stepped surface design serves two purposes: it creates an **anti-rotation lock** and **enhances the side load capacity**.
- Welded to the rails support, this clip requires no access from below.

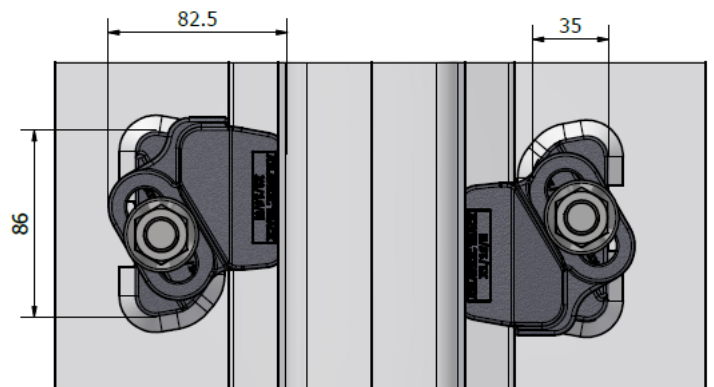

Clip Name	X (mm)	Y (mm)	Z (mm)	Weight (Kg)
X1-16-L	33	28	53	0.71
X1-16-M	33	36	53	0.77
X1-16-H	33	43	53	0.81



## In-situ system Compatibility

In certain instances, the semi-refurbishment of existing systems may only necessitate the replacement of clip caps. Atlantic Track's unique stepped design offers numerous advantages while ensuring compatibility with a wide range of existing systems available in the market.

For more information regarding clip cap compatibility with your existing system, please contact Atlantic Track technical team.

## Rail Compatibility

We offer a range of clip height options that cater to different rail sizes and mounting types, including both pad-mounted and hard-mounted rails. The vulcanized rubber block size can be adjusted to precisely align the clip with the rail and exert a controlled vertical force on it. If you need help in choosing the appropriate clip height variant, please reach out to Atlantic

**The clip can be used for a wider selection of rails than illustrated.** Please contact Atlantic Track International for the full range of possible rails. Atlantic Track may change or improve their products and also alter specifications without notice.

## Installation Instructions

Weld all round the clip base with a 5mm throat thickness fillet weld, using low hydrogen electrodes. Recommended electrodes AWS E7018 or E7028. The clip base is made from weldable grade steel.

**\*For rail without pad** - Weld along the front edge must be omitted, as illustrated.

**Bolt Size – M16 (Grade 8.8) or 5/8" Imperial, 40mm long**, should be used accompanied with a flange nut to secure the clip cap and base.

Bolts should be **torqued to 200 N.m**

Please contact Atlantic Track for full installation instructions.

