



Clip Specifications		
Bolt Grade	8.8	10.9
Max Side Load Capacity (kN)	75	100
Bolt Torque (Nm)	390	600
Horizontal Rail Adjustment (mm)	16	

Product Description

The R201-16 adjustable crane rail clip from Atlantic Track is specifically engineered to secure light rails in challenging environments. Its compact design enables compatibility with cranes equipped with guide rollers.

With its trusted '**double wedge**' mechanism, this clip ensures **automatic locking** and tightening when subjected to a load, effectively securing the rail laterally. Additionally, a specially designed vulcanized rubber nose applies a controlled force to the rail for enhanced stability.

Dimensional data

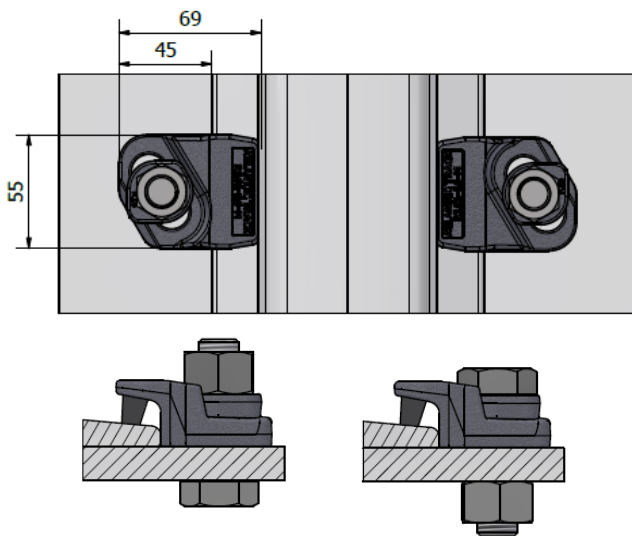

The hexagon headed fixing bolt can be inserted from above or below the supporting structure.

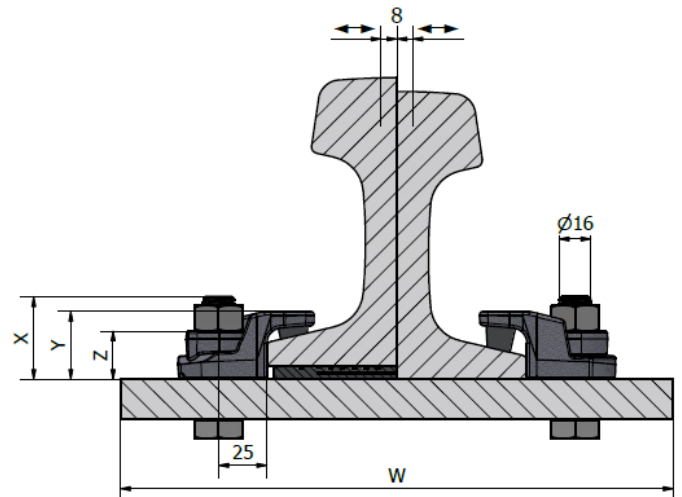

Ref N.	X (mm)	Y (mm)	Z (mm)	Weight (Kg)
R201-16-H	42	28	25	0.30
Minimum Plate Width (B) = Rail width + 100mm				

1. Clip with integral rubber block 2. Special washer

Features

- The distinctive washer design developed ensures proper engagement of the clip, washer, and bolt with the rail, **preventing loosening**.
- The washer was specifically designed to facilitate **easy and intuitive installation** while ensuring compatibility with **M20 bolts**.
- Drain hole to **prevent build-up** of contaminants and standing water.

The clip is designed to be compatible with a wide variety of rails, encompassing those that offer an 8mm to 20mm gap between the top of rail foot and the clip nose, which is the point of contact. Atlantic Track provides appropriately sized noses to ensure a proper fit.

Please contact Atlantic Track International for the full range of possible rails.