

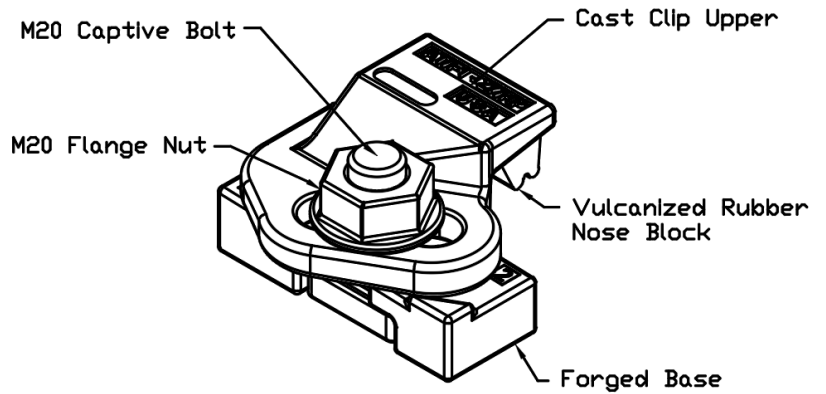

Clip Specifications

Max Side Load Capacity:	37 Kips (165kN)
Horizontal Rail Adjustment	21mm (5/8") Total
Approximate Clip Weight	2.8 bs (w/ Hardware)
Bolt Torque	259 ft/lbs



The Atlantic Track F1-37 Adjustable Crane Rail Clip is designed specifically to fix Crane Rail mounted on a narrow support beam or plate.

The low profile design allows this clip to be fitted on rail systems supporting cranes equipped with guide rollers.

- This proven design has been used successfully for many years throughout the world.
- The clip base is welded to the rail support. No access is required from below.
- The two components are locked together (structural friction connection) by properly torquing the grade 10.9 Captive Bolt.
- The clip has a self-tightening mechanism.
- A special vulcanized rubber nose block applies a controlled downforce to the rail.

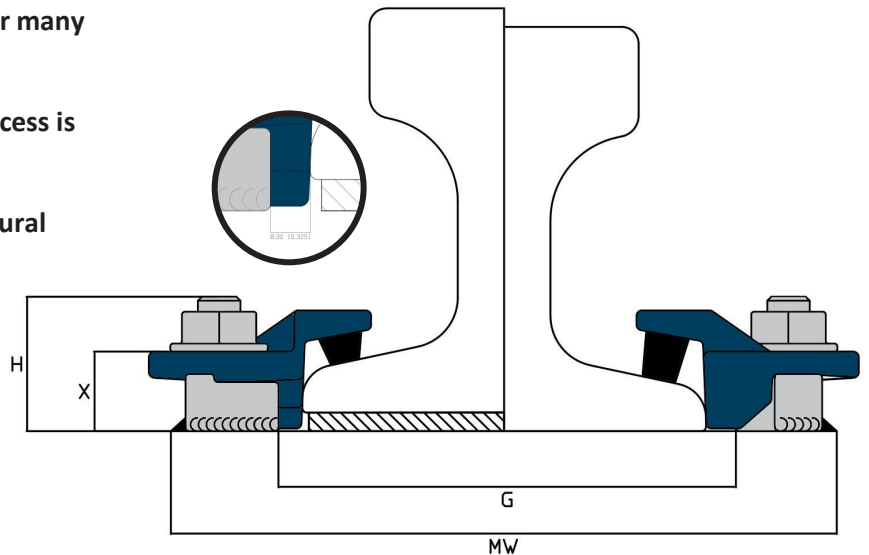

Assembly Dimensions

Clip Gauge (G)	Rail Base + 0.63"
Minimum Mounting Width (MW)	Rail Base + 3.94"
Clip Dimensions	H = 2.2" X = 1.2"

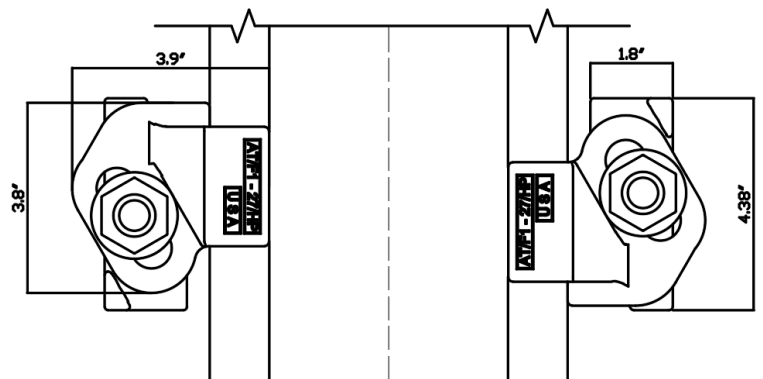

Engineered and Manufactured in the USA

1001 James Drive, Suite B37 • Leesport, PA 19533 • Phone: 610-916-2840 • Fax: 610-916-0898

Atlantic Track reserves the right to discontinue or change specifications or design at any time without prior notice and without incurring any obligation whatsoever.



	Base (B) Inches	Height (H) Inches	Head Width (W) Inches	Suggested Minimum Mounting Width (MW) (Inches)	AT/F1-37 Pad Mounted	AT/F1-37 No Pad
ASCE 60	4¼	4¼	2¾	9¾	F1-37/60P	N/A
ASCE 80	5	5	2½	10½	F1-37/80P	N/A
ASCE 85	5 ³ / ₁₆	5 ³ / ₁₆	2 ⁹ / ₁₆	10⅝	F1-37/85P	N/A
104 CR (MRS51)	5	5	2½	10½	F1-37/104P	F1-37/104NP
105 CR (MRS52)	5 ³ / ₁₆	5 ³ / ₁₆	2 ⁹ / ₁₆	10⅝	F1-37/105P	F1-37/105NP
135 CR (MRS67)	5 ³ / ₁₆	5 ³ / ₁₆	3 ⁷ / ₁₆	10⅝	F1-37/135P	F1-37/135NP
171 CR (MRS85)	6	6	4.3	11½	F1-37/171P	F1-37/171NP
175 (MRS87B)	6	6	4¼	11½	F1-37/175P	F1-37/175NP
MRS87A	6	6	4	11½	F1-37/MRS87A-P	F1-37/MRS87A-NP
DIN A65	6.89	2.95	2.56	11⅜	F1-37/a65P	N/A
DIN A75	7.87	3.35	2.95	13⅜	F1-37/a75P	F1-37/a75NP
DIN A100	7.87	3.74	3.94	13⅜	F1-37/a100P	F1-37/a100NP
DIN A120	8.66	4.13	4.72	14⅜	F1-37/a120P	F1-37/a120NP
DIN A150	8.66	5.91	5.91	14⅜	F1-37/a150P	F1-37/a150NP

Welding and Installation Guidelines

- Mark out and position clip base across rail centerline according to 'G' dimension on this Data Sheet.
- Weld all around the clip base with a 1/4" fillet weld, using low hydrogen electrodes. Recommended electrodes include AWS E7018 or E7028. Clip base is manufactured from weldable forged steel.

***For Clip Installation on systems without a Rail Pad, the weld closest to and parallel with the rail must be adapted or omitted. Please contact Atlantic Track for additional weld detail when pad is not to be used.**

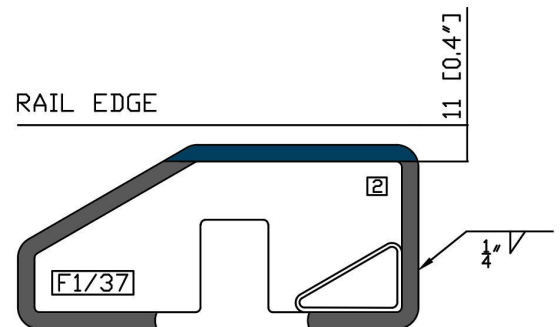

- Do not apply coatings to the contact surface between upper and lower components. Consult with Atlantic Track prior to painting or coating any component.
- For complete installation guidelines, please contact Atlantic Track for the applicable Technical Bulletin.

Engineered and Manufactured in the USA

1001 James Drive, Suite B37 • Leesport, PA 19533 • Phone: 610-916-2840 • Fax: 610-916-0898

Atlantic Track reserves the right to discontinue or change specifications or design at any time without prior notice and without incurring any obligation whatsoever.

Technical Weld Details

The Atlantic Track F1-37 Crane Rail Clip has been designed to take lateral forces from crane rails. It consists of an upper part which has a feature to contact the side of the rail, a vulcanized rubber nose block which bears down on the rail and one Grade 10.9 captive bolt which fasten the two metal parts together. The designed lateral load for the clip is dependent on the amount of weld that is used to attach the lower part to the rail support. It is also dependent on other features of the design of the clip.

Atlantic Track has carried out calculations, using AISC Manual (Allowable Stress Design Method), to determine the allowable load. The calculations below show that with the recommended amount of weld the clip can carry a lateral load (allowable load) of 37 kips. Atlantic Track has undertaken a range of tests done independently. Based on the results of these tests and consideration of the rails that can be fixed with this clip, the Atlantic Track Technical Data Sheet shows a lateral load capacity of 37 kips.

Welding Instructions:

Weld all around the clip base with a 1/4" fillet weld, using low hydrogen electrodes. Recommended electrodes include AWS E7018 or E7028. The Clip base is manufactured from weldable forged steel. Throat thickness cannot exceed 5mm. **For Clip Installation on systems without a Rail Pad, the weld closest to and parallel with the rail must be adapted or omitted.**

Atlantic Track F1-27 Rail Clip Calculations:

Total length of 1/4" fillet weld = 10 inches.

Available strength of weld is determined in accordance with AISC (American Institute of Steel Construction Manual) specification using section J2.4 and table J2.5.

Nominal load capacity of weld, $R_n = 0.6 \times F_{EXX} \times 0.707 \times D/16 \times l$

Where, $F_{EXX} = 70$ ksi

D - weld size in sixteenth of an inch

l - weld length, inches.

Nominal load capacity of weld, $R_n = 0.6 \times 70 \times 0.707 \times 4/16 \times 10 = 74.23$ kips.

Available strength / Allowable strength using ASD method, $R_n/\Omega = 74.23 / 2 = 37.115$ kips.

Where $\Omega = 2.00$, safety factor.

Atlantic Track suggested maximum load considering both the calculated value and the results of tests = 165kN or 37 kips

Atlantic Track normally test clips to twice the specified allowable load. Some clips have been tested to loads higher than twice the design load to determine their suitability for use in nuclear installations.

